

# **User Guide**

**95W waterproof PoE Splitter**

## Package Contents

Check the following contents of your package:

- PoE Splitter (Tape terminal) x 1
- User Guide x 1
- Wrench x 1
- Accessories (water joint x 3)
- DC-DC Power Cable x1

If any part is lost and damaged, please contact your local agent immediately.

## Introduction

This Product is a Gigabit IP67 waterproof PoE Splitter independently developed by our company. It supports 95W input (IEEE802.3bt), supporting up to 60W output, without configuration, plug and play.

Professional room shell design, adapted to various harsh environments, with high stability, reliability, industrial level, wide temperature. The whole machine does not need power adapter, so it is convenient for harsh outdoor environment . reliable power for outdoor work AP, cameras etc.

## Features

- Complies with IEEE802.3, IEEE802.3u, IEEE802.3ab, IEEE802.3af, IEEE802.3at , IEEE802.3bt Standards;
- Data and power carried over the same cable;
- Support Plug-and-play for the devices, without any configuration;
- PD voltage input range 44~56V , power 95W;

## Hardware Description

### Front Panel

The front panel composed by PD IN port , Data out port and relevant indicator, as shown below:

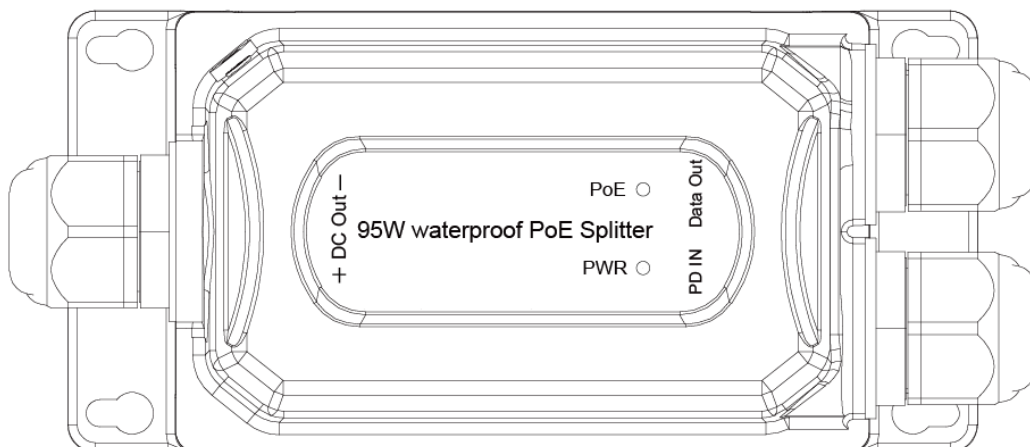

## LED indicator

LED	Color	Function
PoE	Green	Off: Abnormal output voltage of PD chip Light: The output voltage of PD chip is normal
PWR	Green	Off: The machine has no output or abnormal Light: Normal output 12V

## Left Panel

Schematic diagram of left panel: output port (DC Out) and grounding column, Standard network Cate5 cable (line diameter 5.5mm).

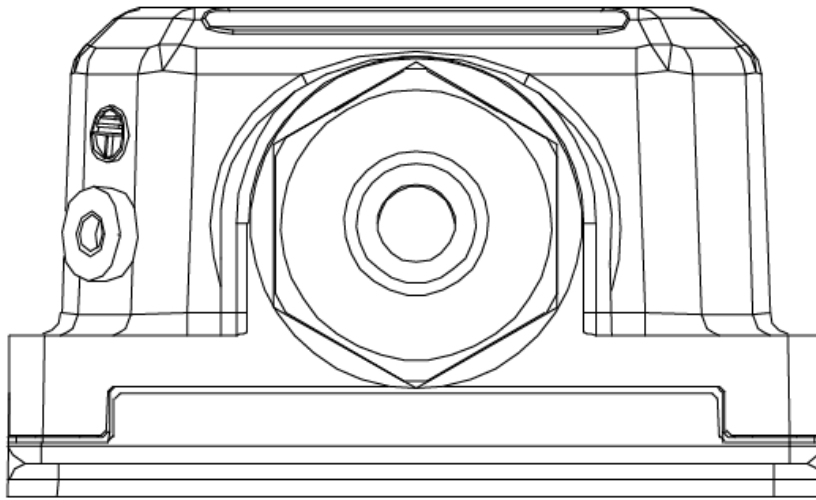

## Right Panel

Schematic diagram of right panel: the Input port (PD IN) and Output port (Data out) requires the use of standard network cate5 cable (Line diameter 5.5mm).

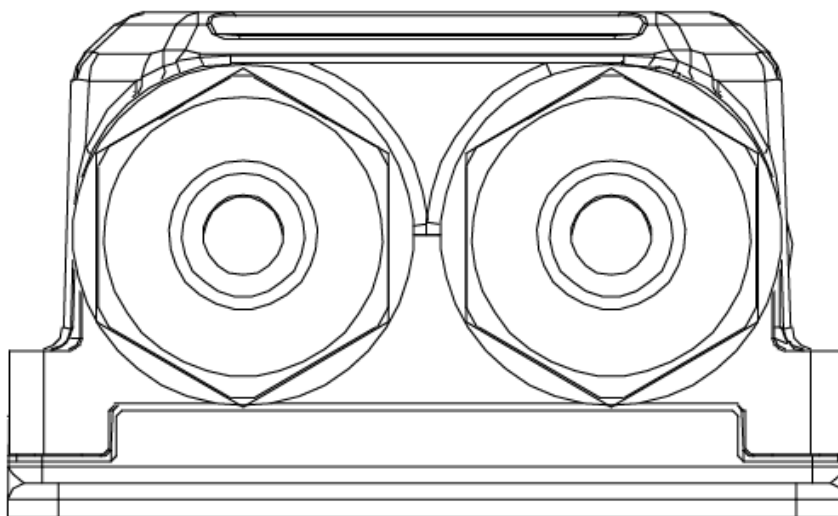

## Installation

This part describes how to install your machine and make connections to it. Please follow the following instructions in avoid of incorrect installation causing device damage and security threat.

- The nuts of the waterproof joint should be tightened in full fit with the joint's thread and fit to the hexagon plane, otherwise it is easy to get water and damage the machine;
- Do not place the machine on an unstable case or desk. The machine might be damaged severely in case of a fall;
- Make sure that the operating voltage is the same one labeled on the machine;
- Do not open the chassis while the machine is operating or when electrical hazards are present to avoid electrical shocks.

## Desktop Installation

Install the machine on a desktop, place the machine carefully on the counter, the bottom is as follows:

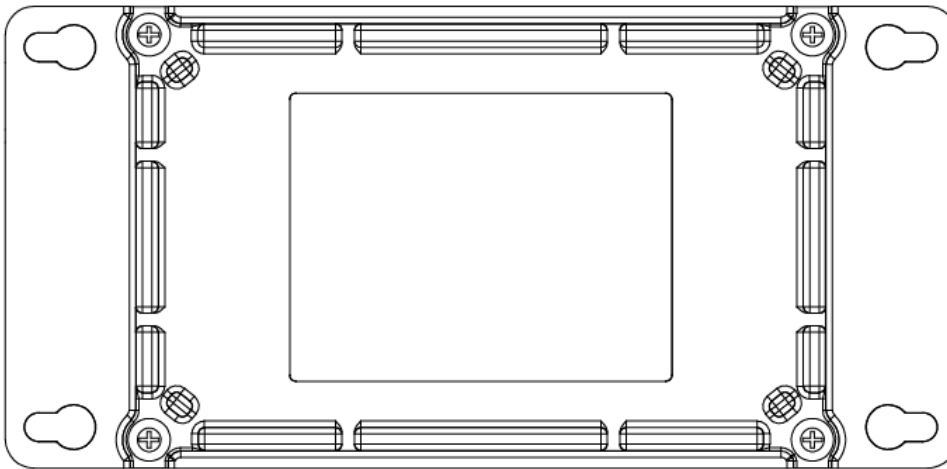

## Wall-mounted installation

Please follow these steps to install the machine:

First fix the four screws on the wall (screw cap diameter recommended 5.5-6.5mm) and turn the machine upside down.

Align the four fixing holes of the machine as shown below and hang the machine smoothly on the screws.

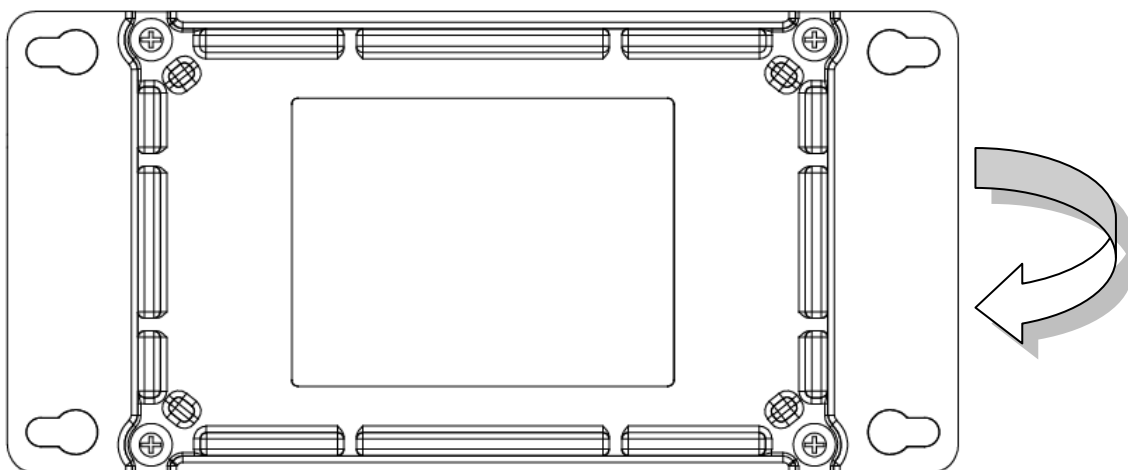

## 4. Connecting the PoE Splitter

You can use 95W PoE Splitter with PSE to expand your network to where there are no power lines or outlets, where you wish to fix devices such as APs, IP Cameras or IP Phones, etc. The following steps will tell you how to connect the PoE Splitter correctly.

1. Use a UTP cable to connect a PoE port of the PSE (ex. PoE Switch) to the PoE port.
2. Connect the LAN port(Data out)to the Ethernet device with UTP cable for data transmitting.
3. Connect the DC Out port to the power port of the same Ethernet device with the provided power cable.

## Specifications

Model	95W waterproof PoE Splitter
Port	1 x 10/100/1000T RJ45 with 802.3at/bt PD IN 1 x 10/100/1000T RJ45 Data out 1 x 2-pin DC out
Standard	IEEE802.3, IEEE802.3u, IEEE802.3ab, IEEE802.3af, IEEE802.3at, IEEE802.3bt
Network Media(Cable)	10BASE-T: UTP category 3,4,5 cable (≤100m) 100BASE-TX: UTP category 5 cable (≤100m) 1000BASE-T: UTP category 5e cable (≤100m)
Dimensions (L*W*H)	150*73*44MM
PoE input	95W Max
power output	DC 12V, 5A max 60W max
PSE Power on RJ-45	1/2 and 3/6, 4/5 and 7/8
Temperature	Operating Temperature: -40° C ~ 75 ° C Storage Temperature: -40 ° C ~ 80 ° C
Humidity	Operating Humidity: 10% ~ 90% non-condensing Storage Humidity: 5% ~ 90% non-condensing
Waterproof rate	IP67
Hazardous rating	IK10